

CATER PRO CART

Detail View

Front View

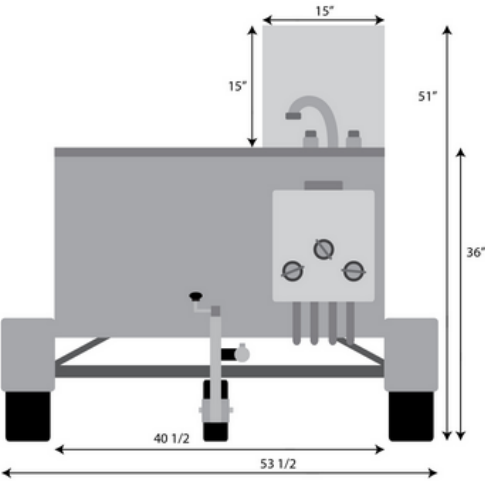

Right View

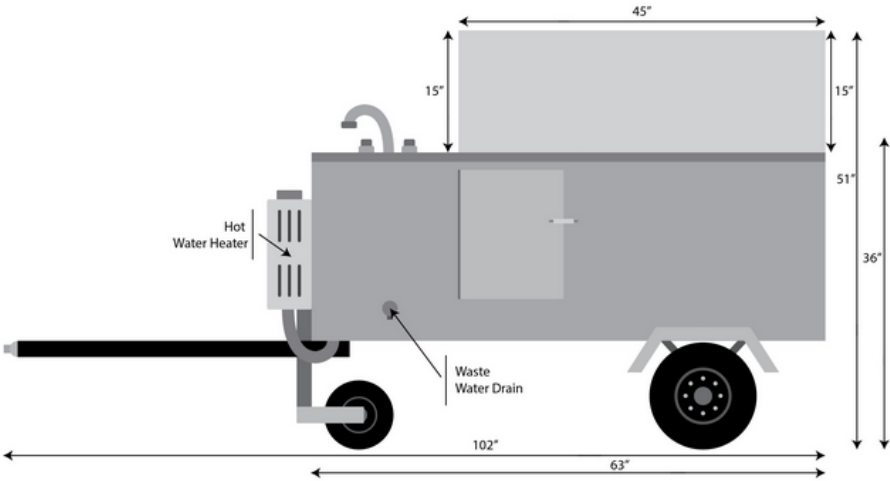

Back View

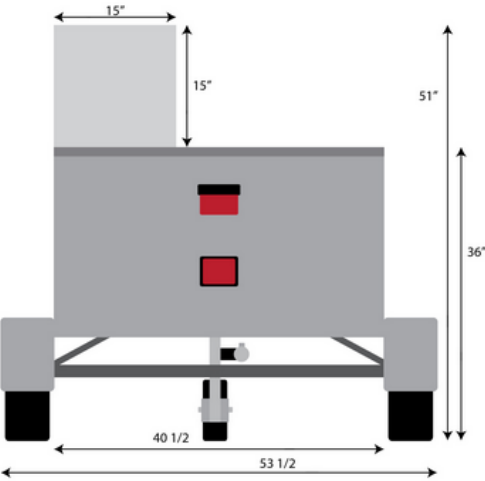

Left View

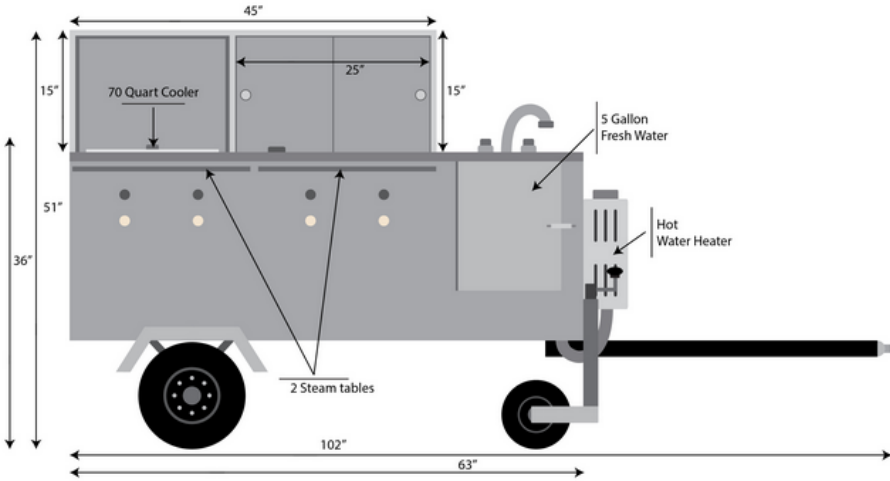

Detail View

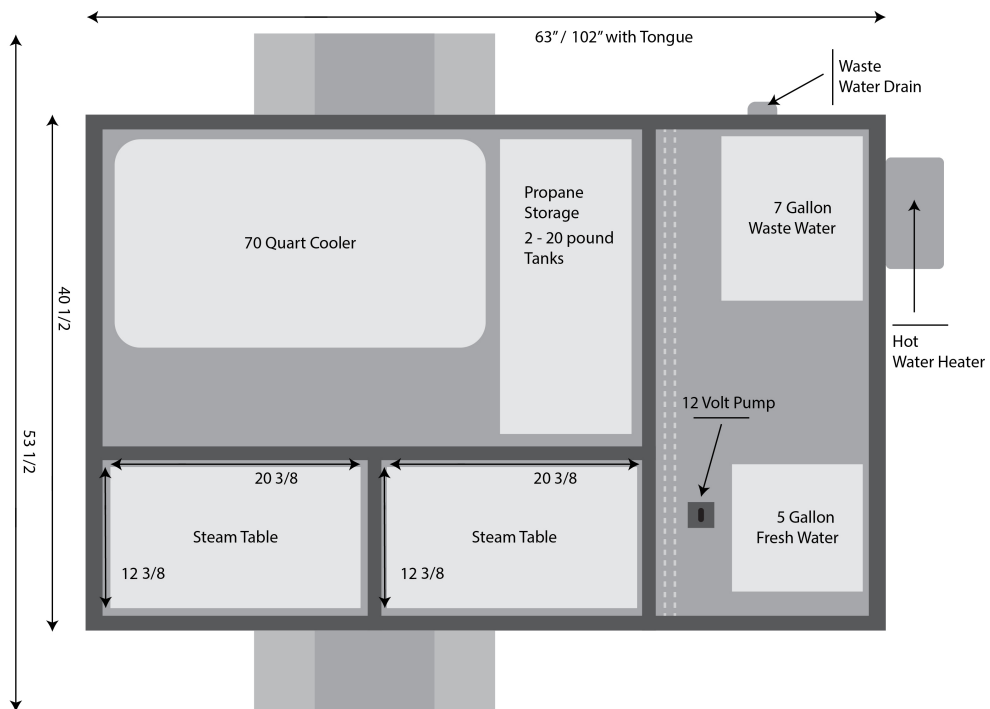
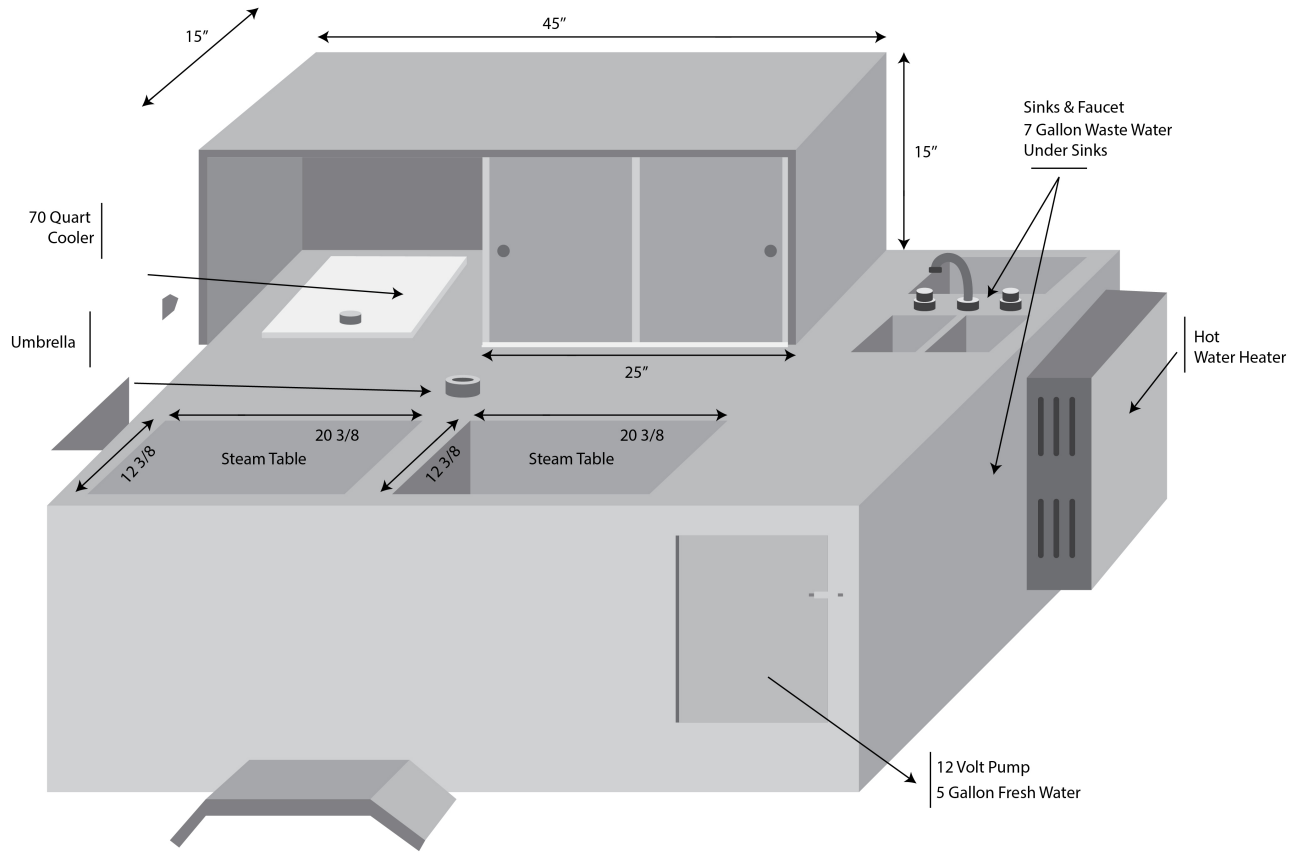

Our NEWEST hot dog cart, The Cater Pro boasts a two commercial steam tables with dual cast iron burners and controls for each. Boil and steam all on the same cart.

DIMENSIONS

- **SIZES:** 63" LENGTH plus 40" removable towing bar
- 40.5" WIDTH (add 15" for fenders)
- 51" HEIGHT
- **WEIGHT:** 347 lbs

ADD IT

- Char Grill
- Commercial Griddle
- Front shelf
- Double deep fryer

TRAILER / TIRES

The cart rests on a D.O.T. Highway approved heavy duty trailer (title included) with baked enamel finish. Bolted and welded construction allows for a super strong structure and will give you many years of use. The leaf spring suspension system allows you to tow it safely at freeway speeds. The tires are standard size 4.8" x 8".

POWER SOURCE

Dual commercial steam tables with twin commercial burners powered by LP Propane Gas. Individual flow control knobs for each burner are standard and allow you to cook more evenly. Burners are lined with holes for even heating and wind resistance. BensCarts uses the best equipment on the market to ensure faithful service from your cart. Enclosed and under the bread box is a hidden storage area for two full size 20# propane tanks. Many states require you have

two propane tanks in case you run out of gas in one, you have a back up. No exposed tanks makes for a safer cart and a professional appearance. A single gas line runs from the burners to the propane storage area and allows you to hook up one tank. A commercial high end LP regulator is included with an easy twist on/off connection.

STEAM TABLE

The steam table can accommodate various size pans with lids. You can use the steamer for hot dogs, buns, chili, cheese, sauerkraut and more. Comes standard with two full sized steam tables which includes; 2 Spillage Pans - One half size perforated pan for steaming, two 1/4th size pans for heating cheese or chili, Three 1/3rd size direct heat pans for boiling or cooking. Includes all lids. All pans and lids are carry the NSF mark. [LEARN ALL ABOUT STEAM TABLES](#)

INSULATION AND VENTING

BensCarts does something no one else will invest in: All carts have triple insulated fireboxes with front rail venting. There will always be heat transference but by investing in a triple heat shield, BensCarts hot dog carts direct the extra heat away from the cart body and cooler area thus saving you money on ice and keeping your cart exterior cooler to the touch.

SINKS AND WATER SYSTEM

The cart comes standard with 4 stainless steel sinks with a hot and cold pressurized water system with no clog drains, a 5 gallon clear water tank and a 7.5 gallon tank for waste water. You can select 1, 2, 3 or 4 sinks at no additional cost during checkout. Sinks are approx. 5"X 6" and 4" deep. Water system, including all fittings and copper and PEX lines are NSF certified. Choosing less sinks will enlarge sinks at no additional cost (for sizes click buy now button). Waste water tank is fixed under the cart body and out of view. It includes a valve for easy draining and comes standard with back flow prevention. Pressure is supplied by the commercial 12v pump. (battery not included) Hot water is supplied via the on-board / on-demand instant hot water heater. For details [click here](#).

TOW BAR

BensCarts sets itself apart by going above and beyond with this fully removable tow bar with a D.O.T. approved 1 7/8" ball coupler and two safety chains. Simply unbolt and remove the tow bar and stow away underneath the cart. This allows you to store your cart in smaller areas. Tow bar should be left in place when setup on location unless used in conjunction with [portable stand](#). Includes tag frame. We recommend placing a serving table over the tow bar if left in place. Most vendors have a portable table anyway and this is a great location for side service. Video - [Learning All About Towing and Trailer Hook Up](#)

WHEEL LEVELING JACK - 3RD WHEEL

Collapsible third wheel is standard and can be adjusted up and down depending on your terrain.

PRESSURIZED WATER SYSTEM

With your 12v. lawnmower or motorcycle battery you can power the included pump that will give you pressurized water. This on demand pump knows when you open the faucet and comes on.

PREP AND SERVING AREA

You will love the extra space on the Cater Pro Hot Dog Cart. To the right of the steam tables is an area for all your prep and serving needs. You can use a condiment caddy (see pro pak in the BensCarts store) or place whatever you need here for serving.

MEAT/BEVERAGE COOLER

This FDA Ch. 4 fully insulated cooler has a hinged lid for easy access. It is rated to hold ice for up to 5 days in 90 degree temperatures. Most vendors don't use this cooler for drinks and store extra dogs and condiments here. You will always need a large cooler for drinks, my freestanding cooler holds 300 drinks.

LIGHTS

As a D.O.T. approved trailer, our carts include stop, turn and tail lights. Wiring harness includes a standard 4 wire flat connection.

BREAD BOX STORAGE

Holding up to 15 bags of 12ct buns and other necessities like napkins, foil and dry condiments. It is solid stainless steel and includes a shelf for a more organized system. Instead of using plexiglass doors, BensCarts upgrades all doors to stainless steel for free, which allows you to keep your supplies hidden from customers view. Plexiglass fades and yellows over time getting these fine hairline cracks and streaks that can make your cart look nasty and old. Stainless steel doors allow for a professional look years from now. Each cart is equipped with two doors for easy access from either side of the cart.

STOW CASE

Below the bread box, depending on how many propane tanks you have is extra storage space accessible from either side of the cart.

UMBRELLA

The huge 9 ft. market umbrella is huge. Allowing for some shade on those hot days. It stands out like nicely for visibility. The umbrella is fabric and its structure is metal to hold up to moderate wind and use. Comes in Red/ or Yellow. See picture on our facebook page or click buy now to see ordering options.

GRILL

A stainless steel grill is available as an upgrade. All states don't allow grills on carts, for details see options tab above or to the right on this page. Mounts in either of two places: (A) off left hand side of steam tables (B) on cart to right of steam tables. [add \$235 or \$285 for left side mount]

Back View

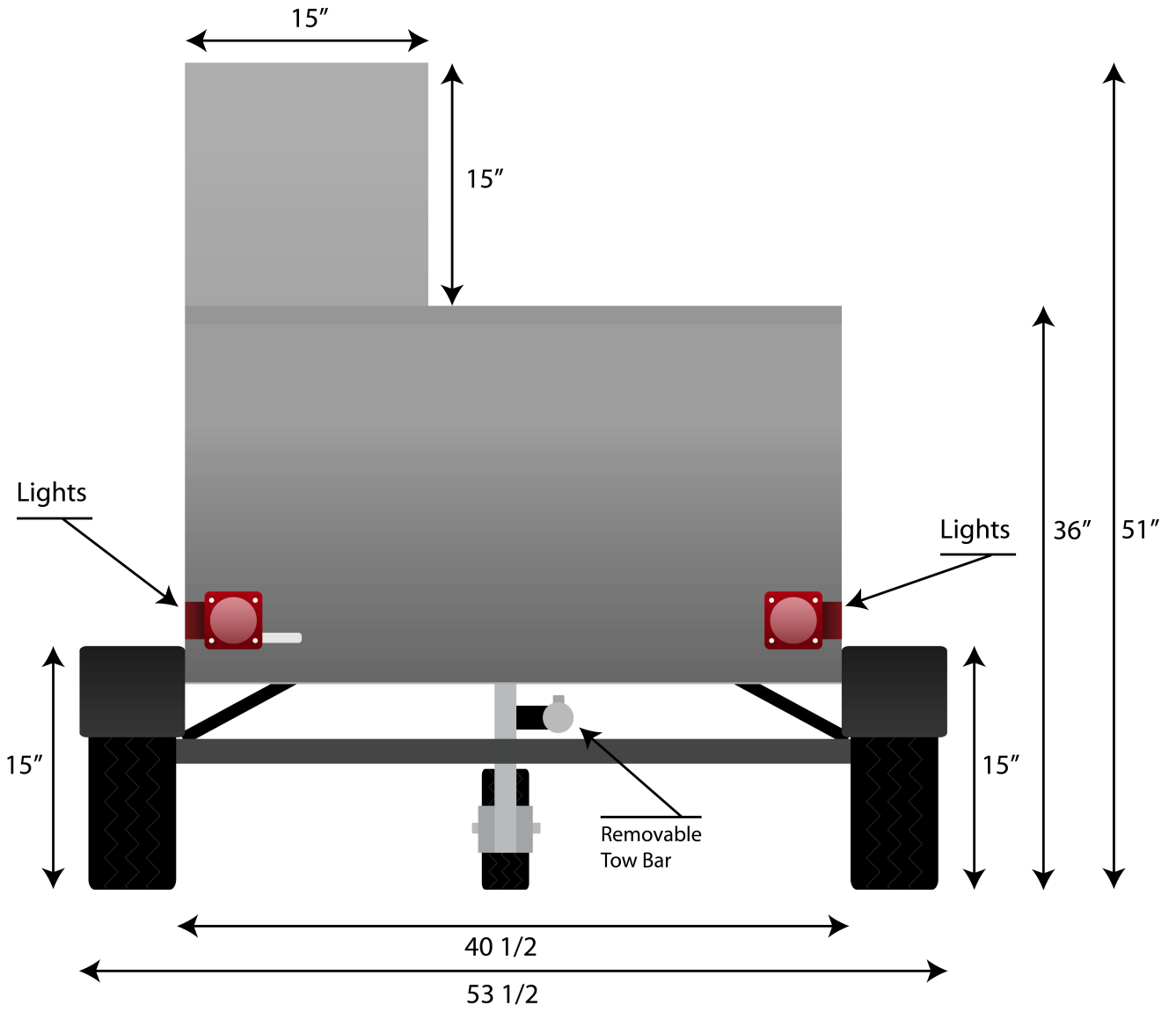

Detail View

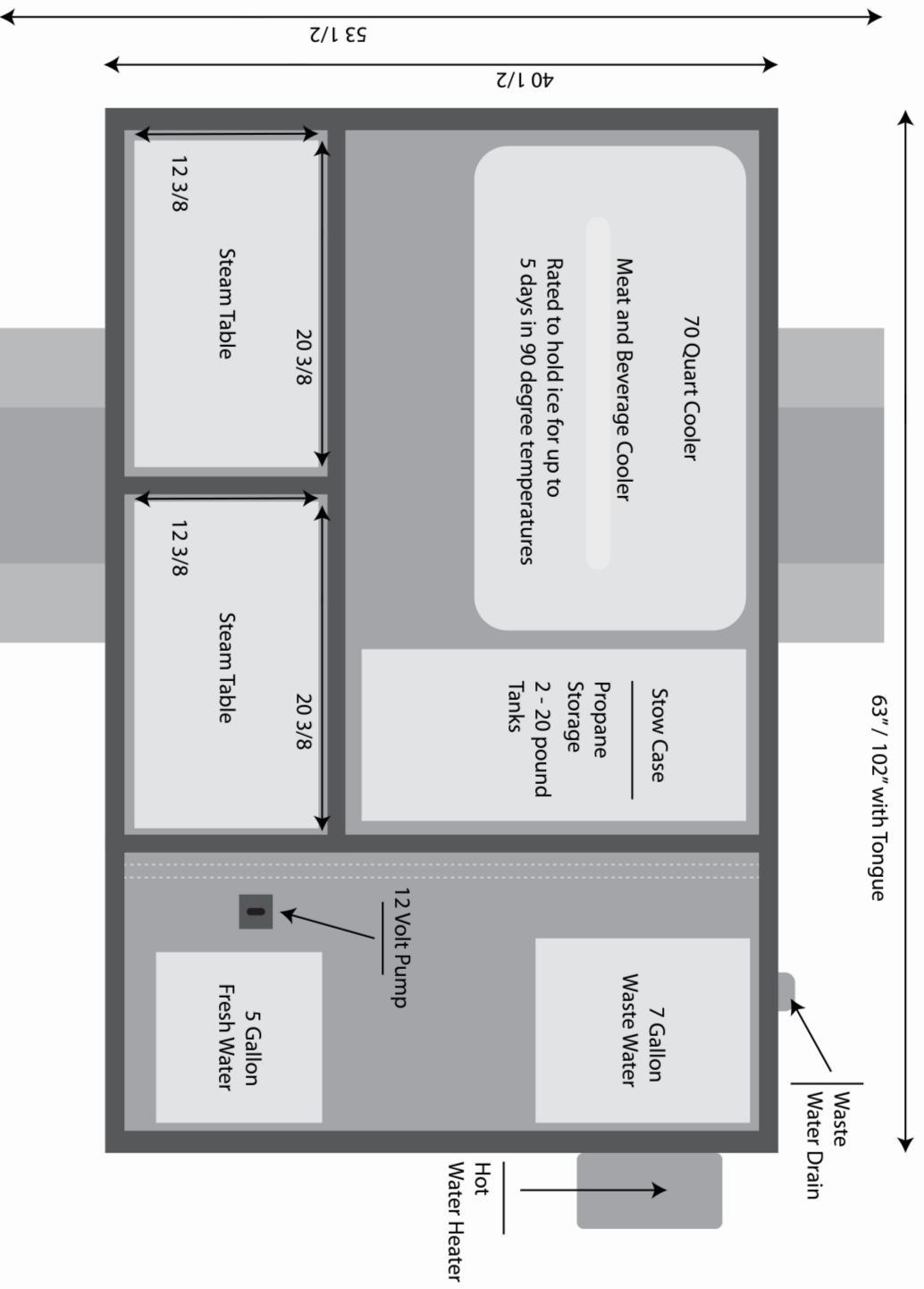

Detail View

Weight : 347 lbs

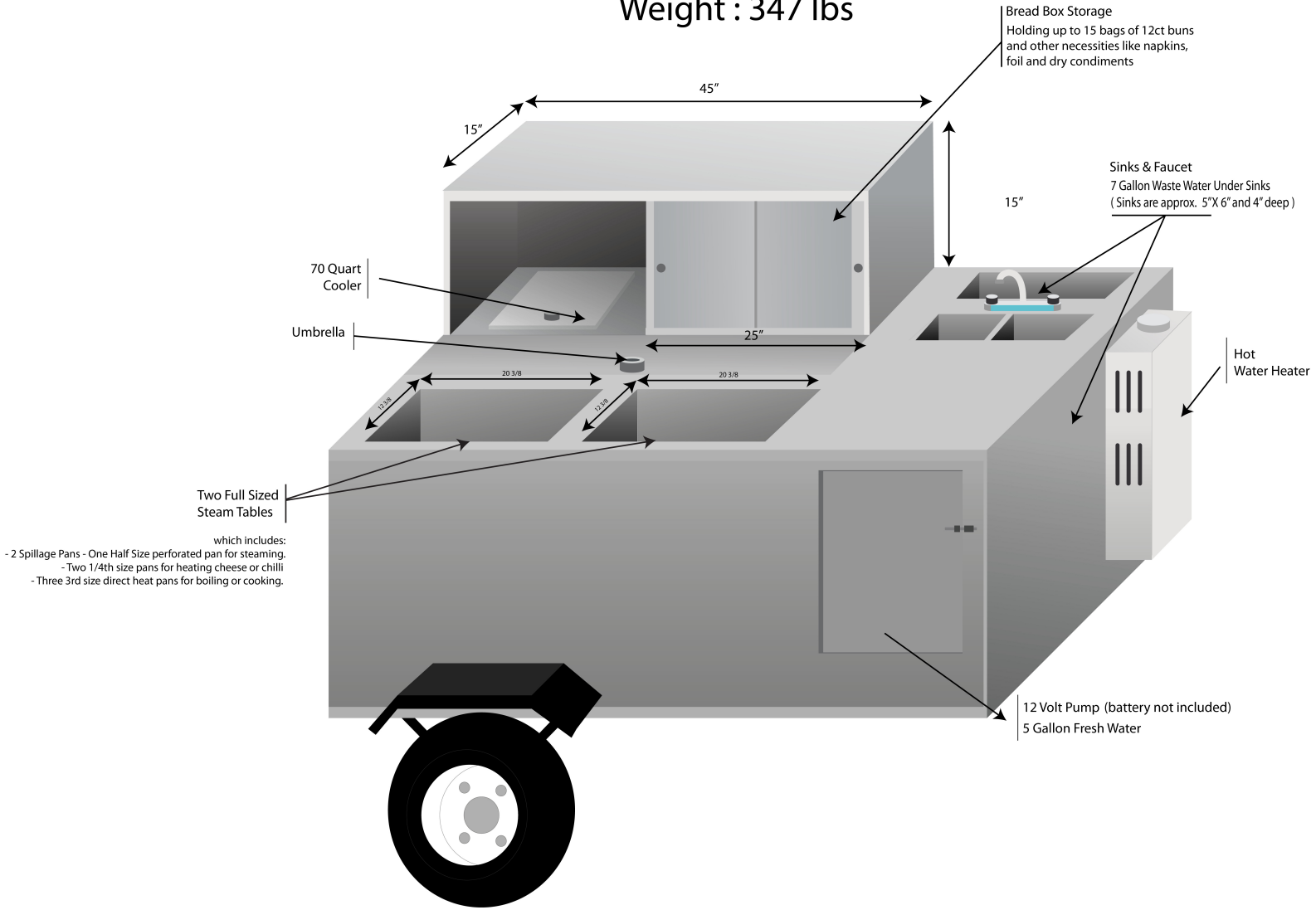

Front View

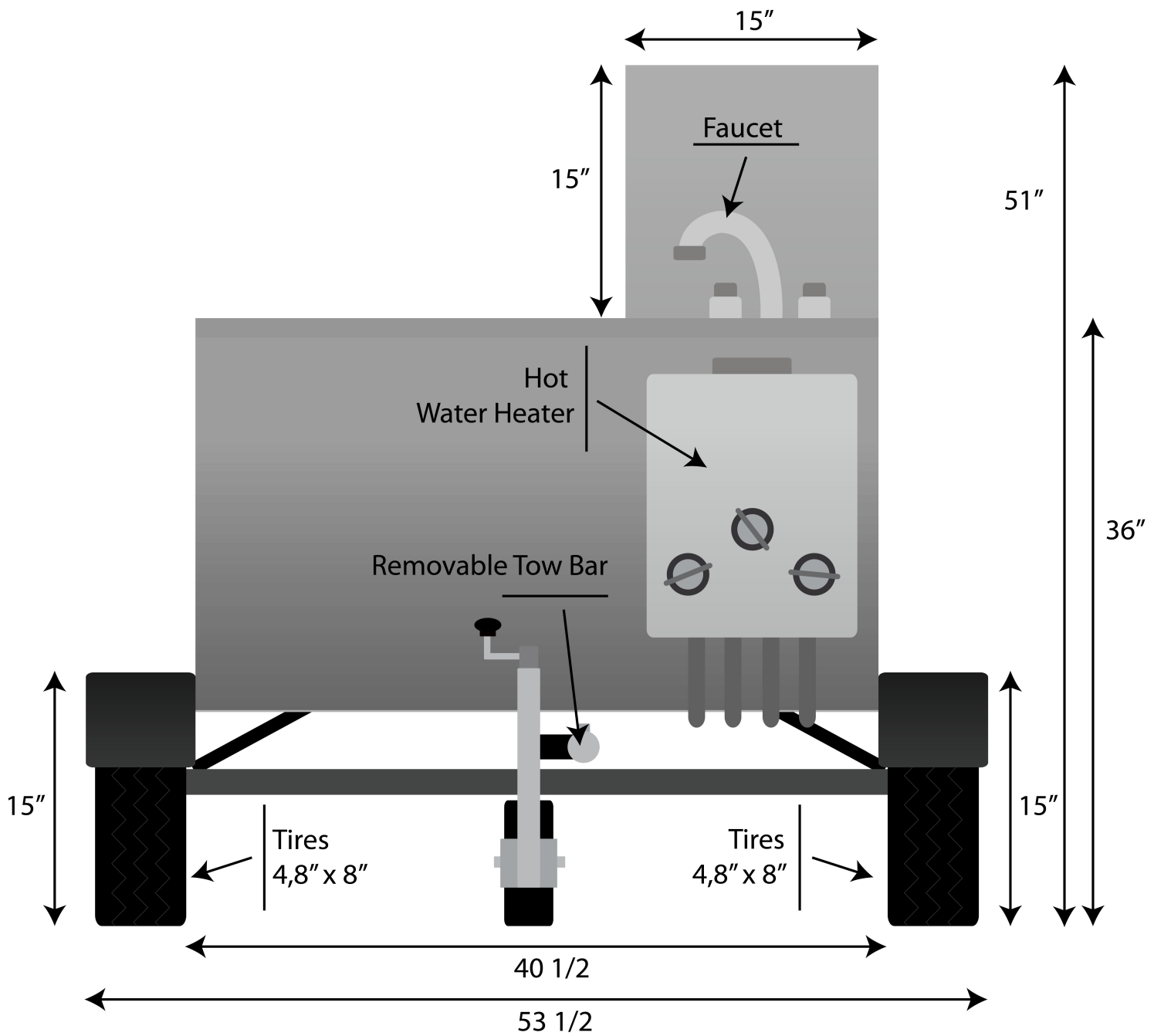

Left View

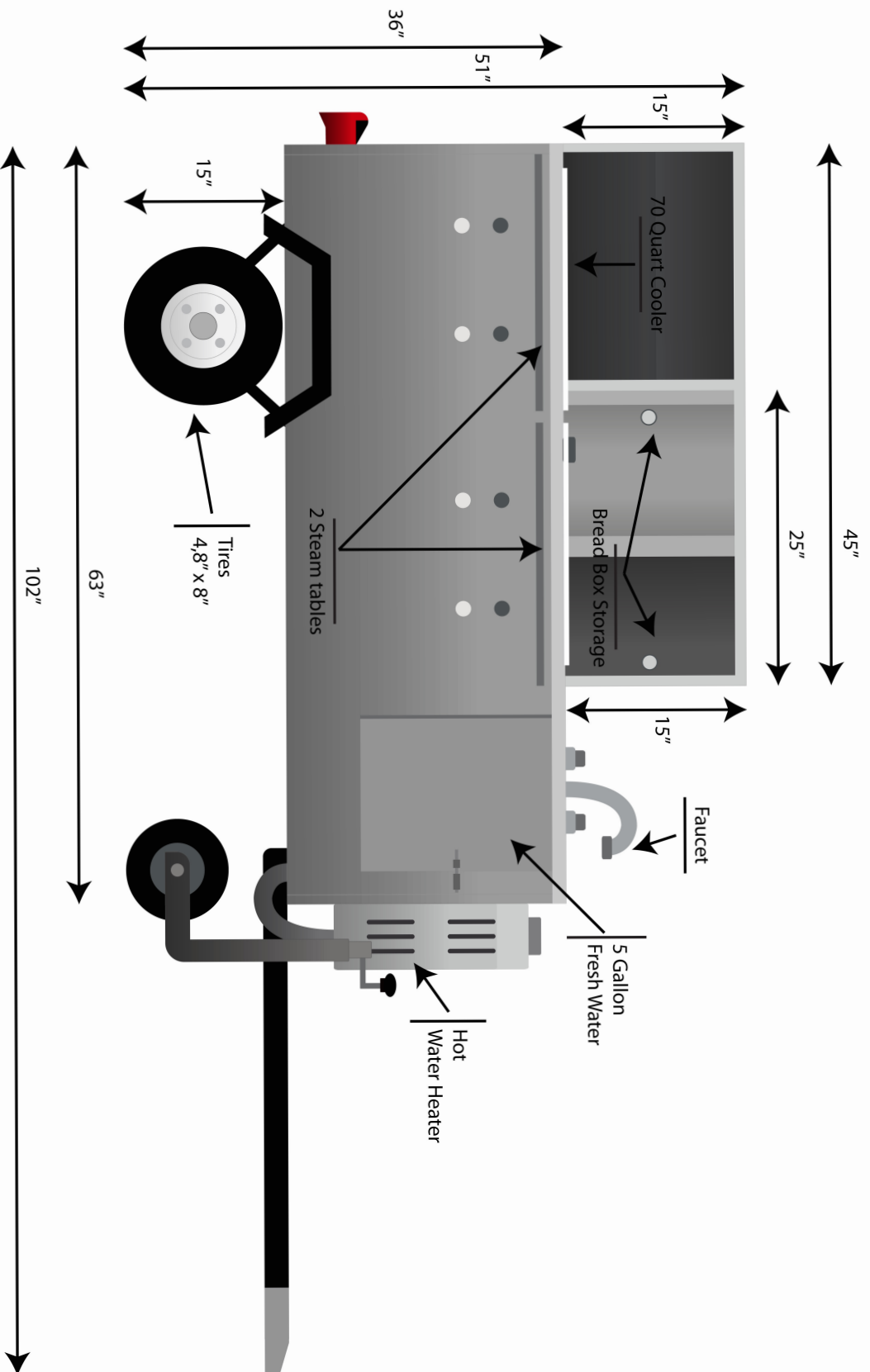

Right View

